

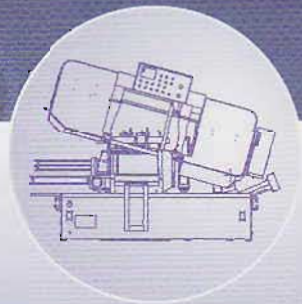

**Bandsaws Of BS Series
With The Best Quality**



Automatic Pivot Bandsaws Machine

BS-250HAS / 300HAS / 400HAS / 450HAS

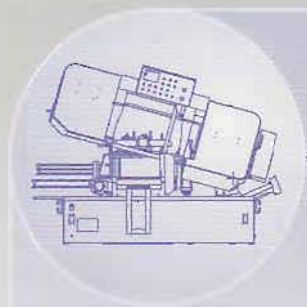

BS-250HAS.GA/BS-300HAS.GA

BS Series Automatic Pivot Bandsaws Machine



A
I
Mo
BS
BS
BS
BS

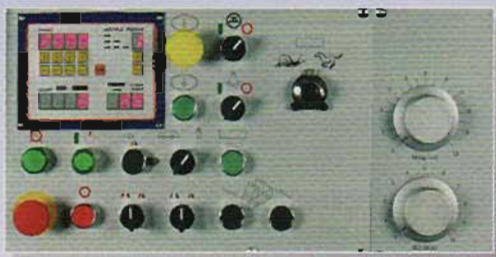

PNC+ Inverter + Amplifying Valve



PNC Control Panel

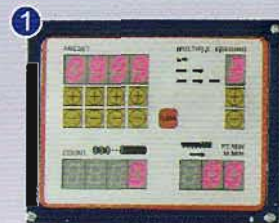
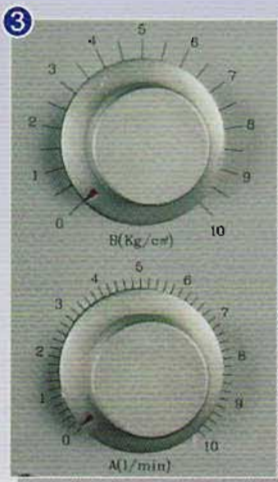

① PNC Control Panel

- ⊙ Cutting Piece Counter
- ⊙ Blade Speed LED-Display
- ⊙ Multiple Stroke Feed Counter

② Inverter Control (Optional)

Easily Operate The Control Of The Cutting Speed.

③ Amplifying Valve (Optional)

Control The Pressure And Flow Rate Of The Cutting Material.

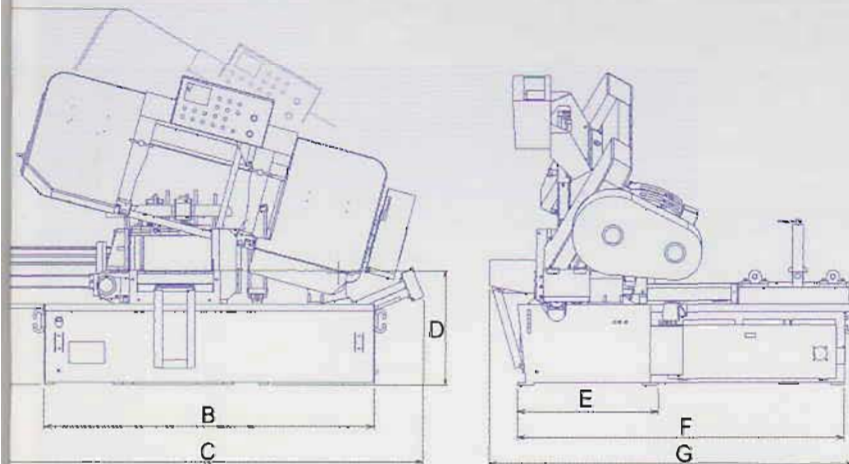

⊙ Two-Way Cylinder

⊙ The Digital Cut Length Counter

⊙ **Optional Accessories**

1. Automatic Chip Conveyor
2. Variable Blade-Speed Drive
3. Variable Vise Pressure System
4. Amplifying Valve For Auto-Adjusting Cutting Feed-Rate
5. Additional Spare Roller Table, Wire Brush, Saw Blade, Work-area Light, etc.
6. GA NC Control

| Item | Unit | A | B | C | D | E | F | G |
|---------|------|-------|-------|--------|-------|-------|-------|-------|
| -250HAS | mm | 1653 | 1550 | 2190 | 593 | 740 | 1772 | 1956 |
| | inch | 65.08 | 61.02 | 86.22 | 23.35 | 29.13 | 69.76 | 77.01 |
| -300HAS | mm | 1761 | 1550 | 2199 | 593 | 740 | 1772 | 1956 |
| | inch | 69.33 | 61.02 | 86.57 | 23.35 | 29.13 | 69.76 | 77.01 |
| -400HAS | mm | 2087 | 1812 | 2024 | 642 | 777 | 1890 | 2207 |
| | inch | 82.17 | 71.34 | 79.69 | 25.28 | 30.59 | 74.41 | 86.89 |
| -450HAS | mm | 2305 | 2033 | 2676 | 704.5 | 868 | 2018 | 2251 |
| | inch | 90.75 | 80.04 | 105.35 | 27.74 | 34.17 | 79.45 | 88.62 |

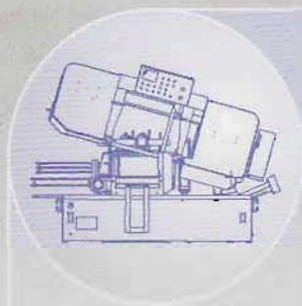

BS-400HAS.GA/BS-450HAS.GA

BS Series Automatic Pivot Bandsaws Machine



Specifications of BS Model

| Item | Unit | BS-250HAS | BS-300HAS | BS-400HAS | BS-450HAS |
|------------------|-------|--|--------------------------------------|----------------------------------|------------------------------------|
| Cutting Capacity | mm | ●260 ■300W x 180H ■280W x 250H | ●330 ■350W x 250H ■300W x 300H | ●400 ■400W x 320H | ●460 ■460W x 407H |
| | inch | ●10 ■12W x 7H ■11W x 10H | ●13 ■13W x 10H ■12W x 12H | ●16 ■16W x 12H | ●18 ■18W x 16H |
| Bundle Cutting | mm | 200W x 140H | 250W x 165H | 320W x 205H | 360W x 255H |
| | inch | 8 W x 5 1/2H | 10W x 6 1/2H | 13" W x 8"H | 14W x 10H |
| Blade Size | mm | 32 x 1.1 x 3660 | 32 x 1.1 x 3820 | 32 x 1.1 x 4115 | 38 x 1.3 x 4880 |
| | inch | 1 1/4 x 0.042 x 144 | 1 1/4 x 0.042 x 150 | 1 1/4 x 0.042 x 162 | 1 1/2 x 0.05 x 192 |
| Motor Output | HP | Blade-3 HYD-1 Coolant- 1/8 | Blade-5 HYD-1 Coolant- 1/8 | Blade-5 HYD-1 Coolant- 1/8 | Blade-7.5 HYD-2 Coolant- 1/8 |
| Blade Speed | M/Min | 25 , 32, 42, 55, 70, 80 Variable Speed 20-80 OPT. | | | |
| | F/Min | 82, 105, 138, 180, 230, 260 Variable Speed 65-260 OPT. | | | |
| Shipping Volume | mm | 2120Lx2090W x1500H | 2120Lx2090W x1600H | 2150Lx2240W x1770H | 2540Lx2270W x1920H |
| | inch | 83.5Lx82.3W x59H | 83.5Lx82.3W x63H | 84.6Lx88.2W x69.7H | 100Lx89.4W x75.6H |
| Weight Net/Gross | Kg | 1380 / 1610 | 1410 / 1640 | 1630 / 1950 | 3100 / 3500 |
| | lb | 3036 / 3542 | 3102 / 3608 | 3586 / 4290 | 6820 / 7700 |

The manufacturer reserves the right to modify the design, specifications or mechanisms, to improve the performances, without prior notice. All the specifications shown here are for reference only.

Standard Accessories Of BS Series

- | | |
|--|---------------------------------|
| ◎ Tools With Tool Box..... 1 set | ◎ Band saw Blade.....1 piece |
| ◎ 7 ft.(2M) Long Roller Table..... 1 set | ◎ Instruction Manual.....1 copy |
| ◎ Band-Cleaning Wire Brush1 piece | |

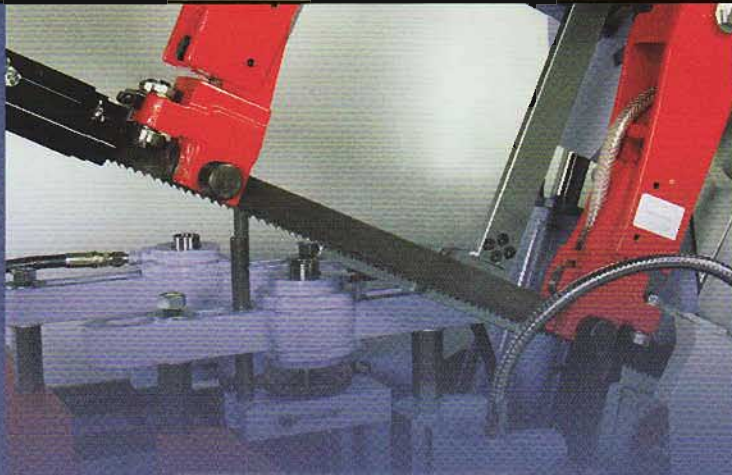

www.bandsaw.com.tw

MEGA MACHINE CO., LTD.

Address: No. 180, Industrial Road, Tai-Ping City, 41154 Taichung, Taiwan, R.O.C.

TEL: 886-4-2271 2877(PRES.) FAX: 886-4-2271 5016

E-Mail: mega@ms1.hinet.net

BS - XXX HAS ———— BS - Automatic Pivot Bandsaws
 XXX - Capacity of Product
 HAS - Properties of Product
 (HAS:Vise Rack Feed / AF:Vise Full Stroke Feed / HAF:Front Vise Full Stroke Feed, Rear Vise Rack Feed)

————— Please inform our company to get the details. —————