

PARAT 4-WAY INDEXING QUICK CHANGE TURRET TOOLING SYSTEM

TURNING INSTEAD OF MEASURING

Indexing accuracy 0,005 mm (.00001")
Internal and external operations in one setting
Quick Clamping System with 40 positions
in divisions of 9°. Now 5 sizes and internal
cooling facility available.

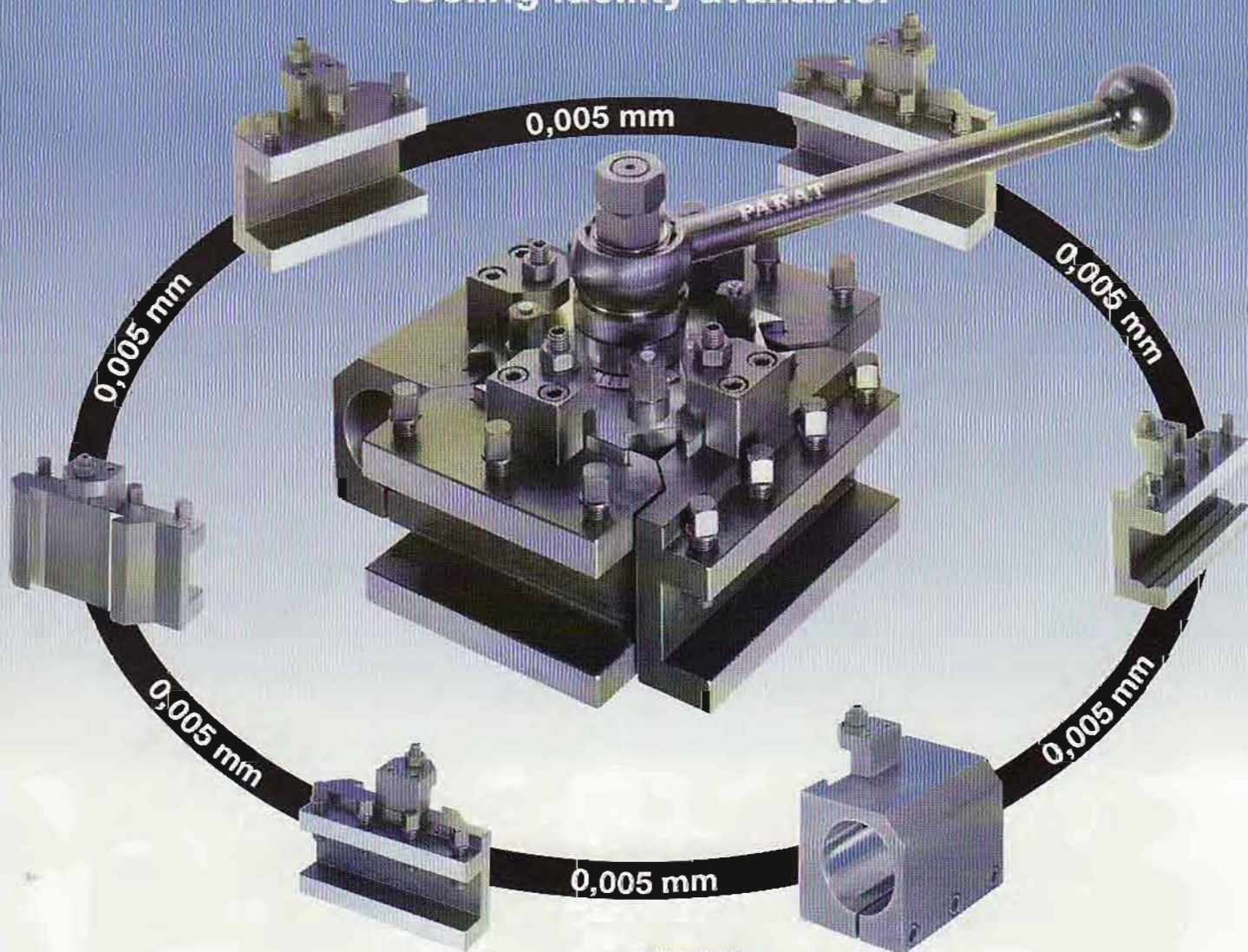

THE PARAT 4-WAY INDEXING TURRET

The manufacture of precision components requires the highest demands from the machine as well as the Tooling System without losing the operator friendliness. Digital readout systems, electronic stops, cycle- as well as CNC-controls enable the user to machine external and internal precision tolerances in only one setting. This is possible without any effort with PARAT in many cases without changing toolholders.

With its four tool stations and indexing accuracy of .00001" (0,005 mm) the PARAT 4-Way Indexing Toolpost offers the ideal solution.

The four clamping surfaces, the guide flute, the patented parallel coupling of the square body, and the Hirth type coupling are precision ground.

The eccentric element allows the clamping of up to 4 toolholders simultaneously.

Opening and clamping of all PARAT Turret Head Systems is carried out by means of a threadless quick clamping nut in unison with a robust quick clamping lever for easy handling.

The friendly operation of the PARAT 4-Way Indexing Turret Tooling System shows up especially in those cases, when a component to be machined requires a number of different tools.

The exchange of toolholders which may have a weight of up to 27,2 lbs. (12,3 kg) without a tool, is not only a tiring but also an energy and time consuming process. This is now reduced to an absolute minimum.

For optimal utility of the different tools PARAT offers a wide range of practical toolholders.

The toolholder which is only partly machined, takes up a special place within the PARAT system. This is a toolholder which is supplied with a doughtail guideway already hardened and ground. The user is able to machine the remaining part to satisfy his own specific requirements.

With the PARAT Universal Quick Change Toolpost with only TWO clamping positions, offset at 90° PARAT offers the entry into the unique PARAT system as an economical alternative to the 4-Way Indexing Turret.

Due to the identical basic concept of the PARAT system, the Quick Change Toolpost with the two clamping positions can easily be exchanged with the PARAT 4-Way Indexing Turret System at any time to satisfy a change of production requirements. Even then the existing toolholders can be utilized within the same size of the PARAT system.

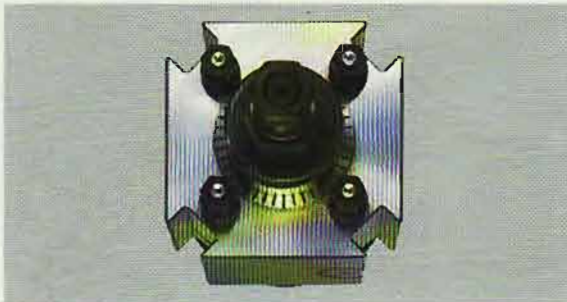

PARAT 4-Way Indexing Turret Head

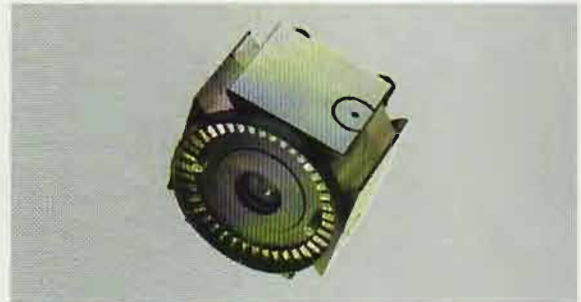

PARAT 4-Way Indexing Head from underneath

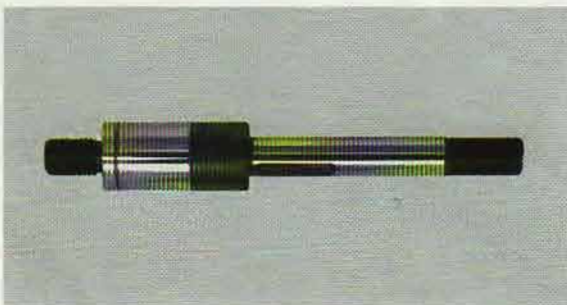

PARAT Clamping Bolt with thread (standard)



PARAT Quick Clamping Nut

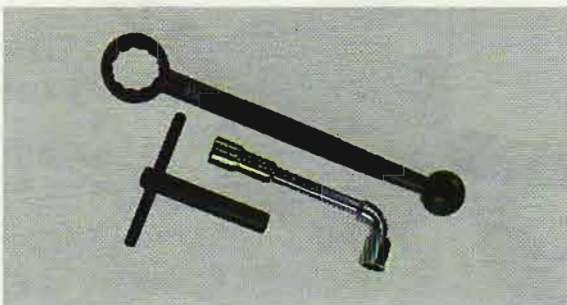

PARAT Operating Tools

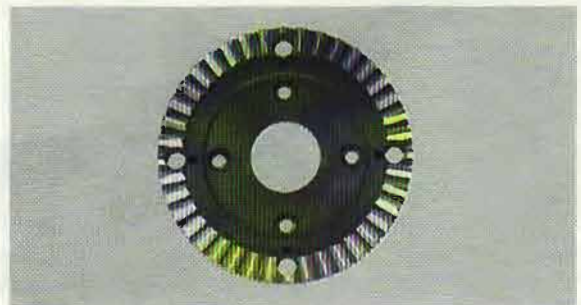

PARAT Precision Ground Coupling

Technical data
to define suitable size

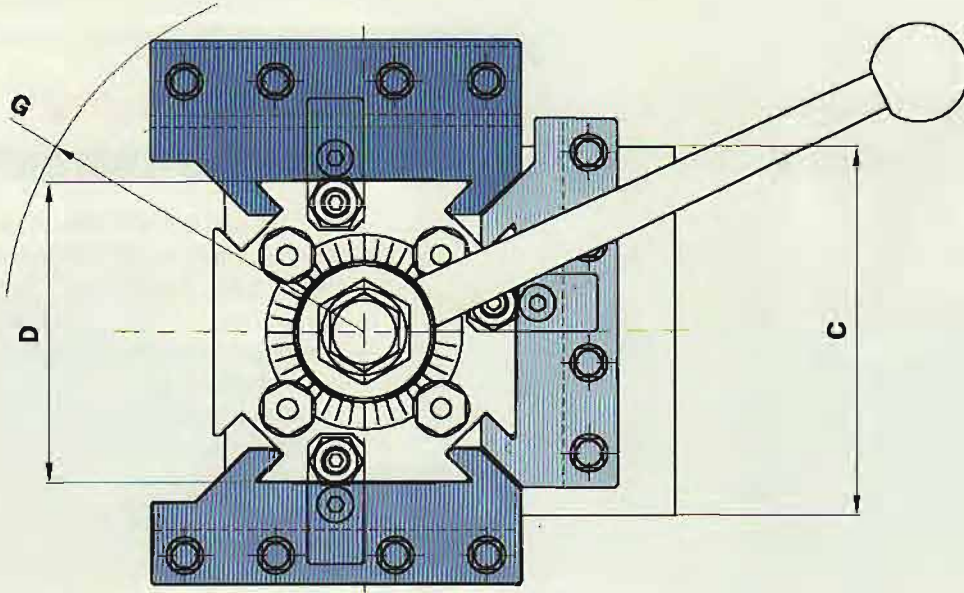
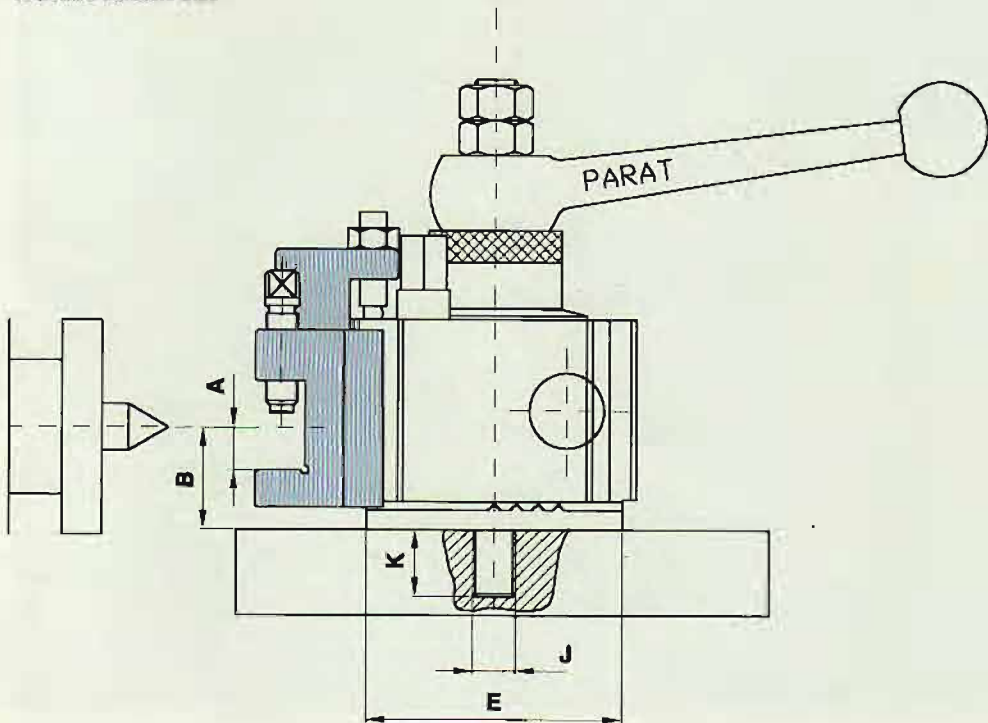

Technical Data	Type	mm/inches Size 1	mm/inches Size 2	mm/inches Size 3	mm/inches Size 4	mm/inches Size 5
Motor output	kw/hp	3,7/5	7,4/10	14,7/20	22/30	30/40
Cutting Tool	A	□ 20/0.7874	□ 25/0.9842	□ 40/1.5748	□ 50/1.9685	□ 50/1.9865
Hight of cutting edge	B	30/1.1811	40/1.5748	60/2.3622	80/3.1496	90/3.5430
Width of top slide	C	90-100/3.5433	110-150/4.3307	150-180/5.9055	200-250/7.874	200/7.874
Basic square toolpost	D	□ 84/3.3070	□ 106/4.1732	□ 134/5.2755	□ 154/6.0629	204/8.0315
Precision coupling	E	Ø 80/3.1496	Ø 102/4.0157	Ø 133/5.2362	Ø 150/5.9055	Ø 195/7.6772
Swing dia. with toolholder	G	Ø 180/7.0866	Ø 240/9.4488	Ø 300/11.811	Ø 350/13.7795	Ø 446/17.5590
Clamping bolt in top slide depth	J	M 14 x 2	M 16 x 2	M 20 x 2	M 24 x 3	M 30 x 2
	K	21	25	30	35	40
Weight kg/lbs.		3,5/7.7	6,5/14.3	15/33	22/48.4	45/99.21

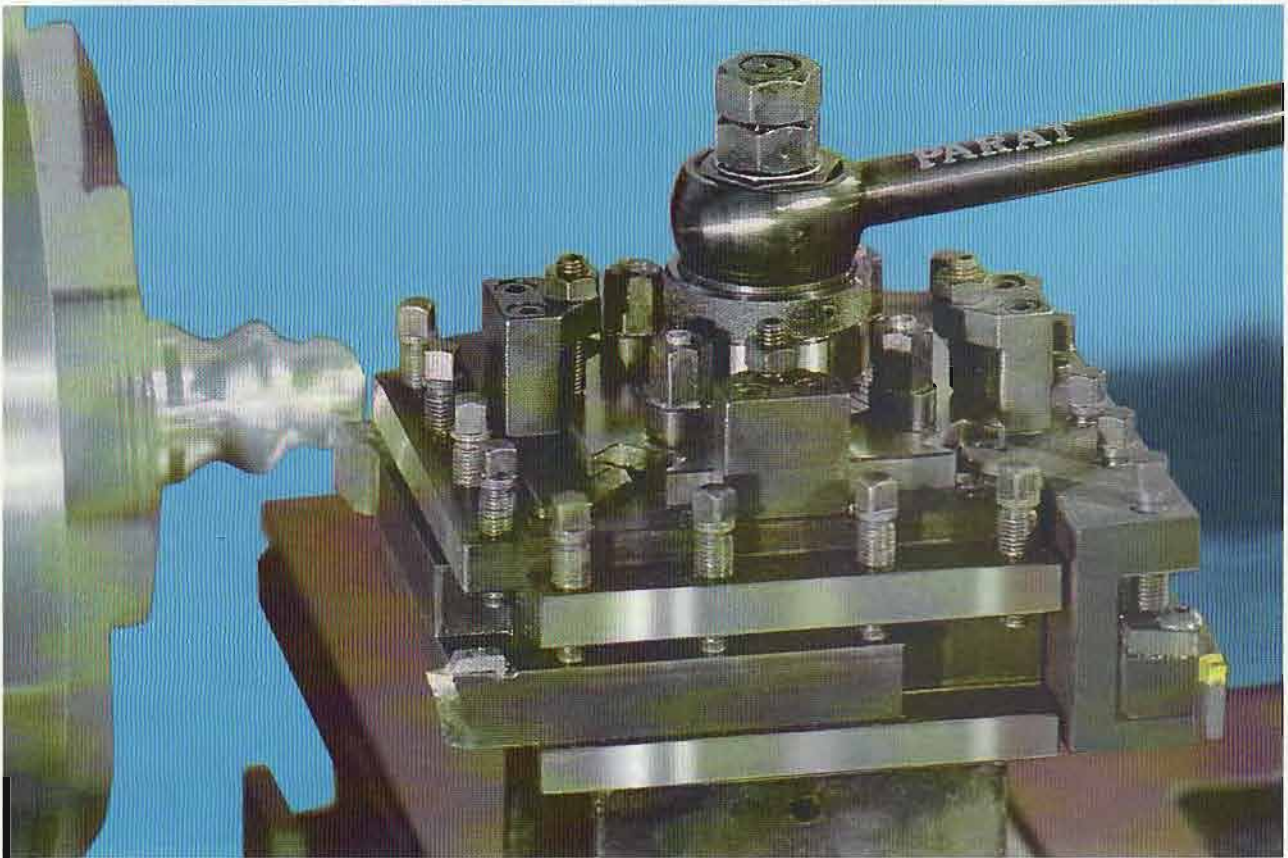

Internal COOLANT

The clamping bolt with internal coolant facility can be utilized for all new but also existing PARAT 4-Way Turret Indexing Systems (option at extra cost).

The above mentioned facility consists of the following elements:

- One Clamping Bolt with internal bore
- two threaded connectors
- One coolant hose
- One straight connector for coolant supply
- One elbow connector for coolant supply
- One plug screw (as illustrated on left)

Order data:

Size	Thread/Measurement "J"
2	M 20 x 2,5
3	M 24 x 3
4	M 24 x 3
5	M 30 x 2

Special clamping bolts are available on request for specific types of machines at extra cost.

PARAT 4-Way Indexing Turret System Size 5 for turning machines with higher motor power

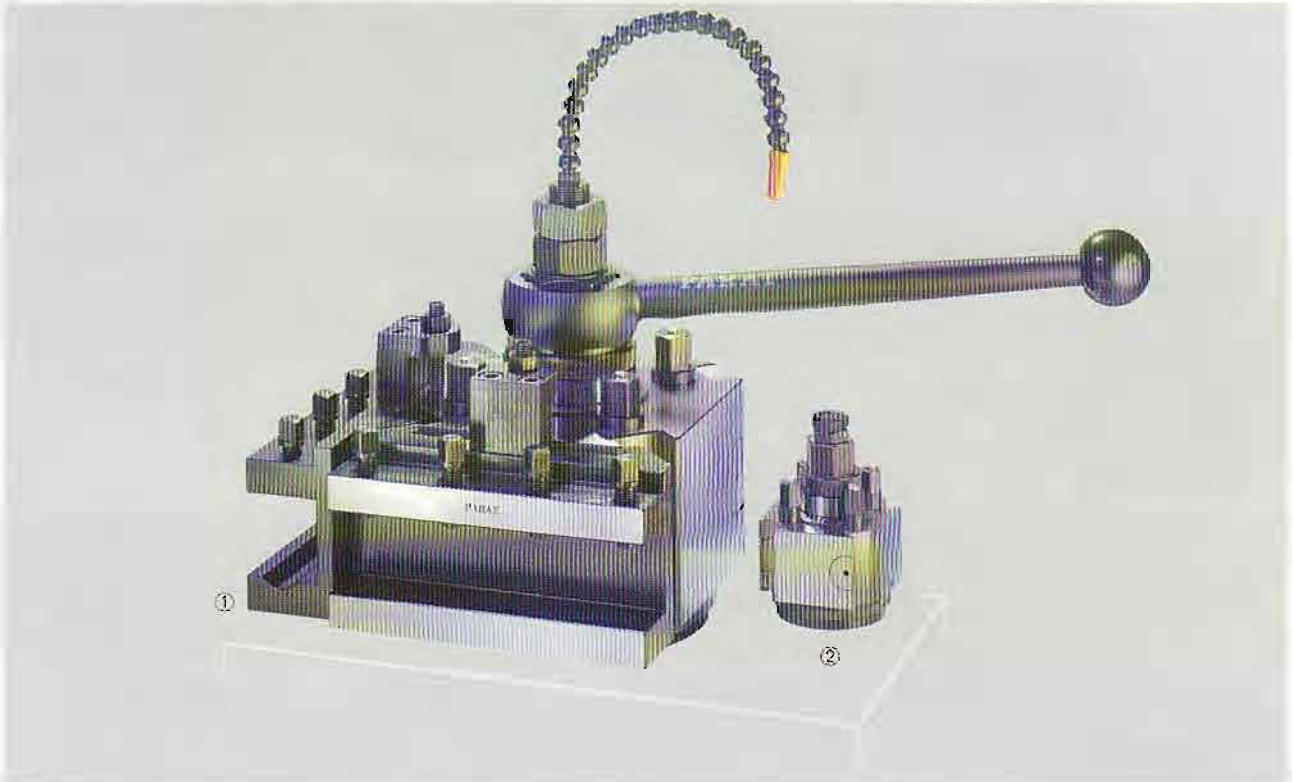

① PARAT-Turret Head Size 5 up to 40 kW ② PARAT-Turret Head Size 1

Lengthened PARAT toolholders utilized correctly 4 examples of how to clamp cutting tools efficiently with short overhang

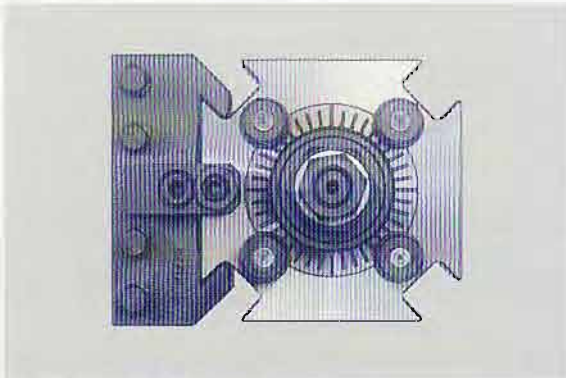

Type RD 2 with toolholder WD 2/25

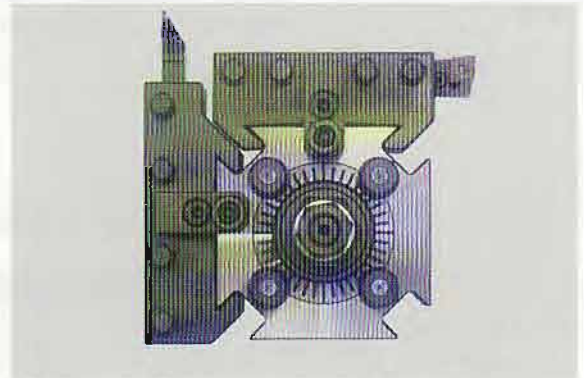

Type RD 2 with toolholder WD 2/25 & WDR 2/25

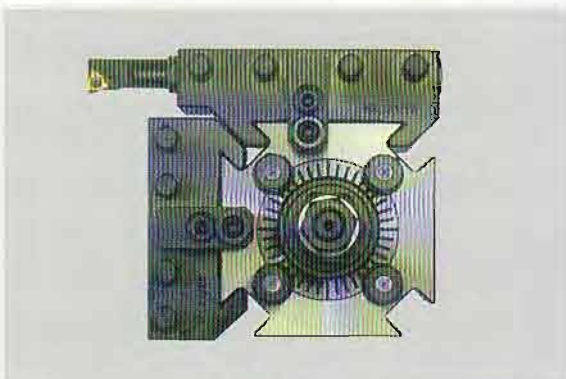

Type RD 2 with toolholder WD 2/25 & WDL 2/25

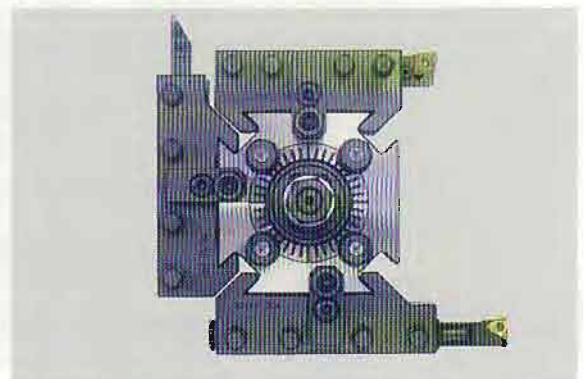

Type RD 2 with toolholder WD 2/25 & WDR 2/25 & WDL 2/25

PARAT toolholders for 4-Way Indexing Tu

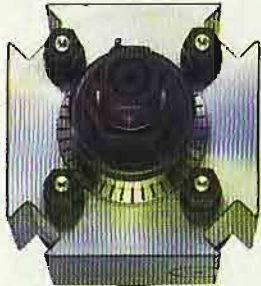
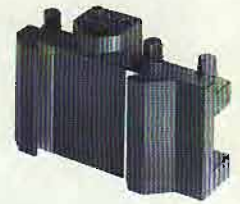
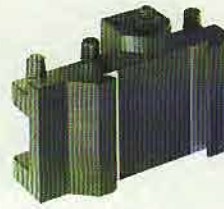

4-Way Indexing Turret
Type RD



Universal System
Type UD

Size	Toolholder WD	Toolholder WDL	Toolholder WDR	Toolholder WDPL
Type RD 1	WD 1/12 WD 1/20	WDL 1/12 WDL 1/20	WDR 1/12 WDR 1/20	WDPL 1/12 WDPL 1/20
Type UD 1				
Type RD 2	WD 2/25	WDL 2/25	WDR 2/25	WDPL 2/25
Type UD 2				
Type RD 3	WD 3/32 WD 3/40	WDL 3/32 WDL 3/40	WDR 3/32 WDR 3/40	WDPL 3/32 WDPL 3/40
Type UD 3				
Type RD 4	WD 4/40 WD 4/50	WDL 4/40 WDL 4/50	WDR 4/40 WDR 4/50	WDPL 4/40 WDPL 4/50
Type UD 4				
Type RD 5	WD 5/50	WDL 5/50	WDR 5/50	WDPL 5/50
Type UD 5				

Toolholders

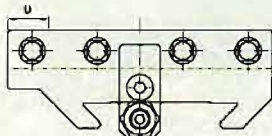
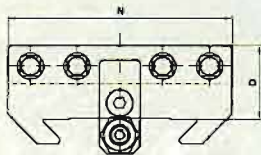

Technical data		mm/inches	mm/inches	mm/inches	mm/inches	mm/inches	mm/inches	mm/inches	kg/lbs.
Size	Type	N	O	P	R	S	U		
1	WD 1/12	84/3.3070	24/0.9448	47/1.8503	14/0.5512	22/0.8661	—	—	0,7/1.54
	WDL 1/12	100/3.9370	24/0.9448	47/1.8503	14/0.5512	22/0.8661	16/0.6299	—	0,8/1.76
	WDR 1/12	100/3.9370	24/0.9448	47/1.8503	14/0.5512	22/0.8661	16/0.6299	—	0,8/1.76
	WD 1/20	84/3.3070	33/1.2992	52/2.0472	20/0.7874	22/0.8661	—	—	0,8/1.76
	WDL 1/20	100/3.9370	33/1.2992	52/2.0472	20/0.7874	22/0.8661	16/0.6299	—	0,9/1.98
	WDR 1/20	100/3.9370	33/1.2992	52/2.0472	20/0.7874	22/0.8661	16/0.6299	—	0,9/1.98
	WDPL 1/12	100/3.9370	28/1.1023	47/1.8503	16/0.6299	22/0.8661	16/0.6299	—	0,9/1.98
	WB 1/30	84/3.3070	39/1.5354	47/1.8503	Ø30/1.1811	—	—	—	0,8/1.76
2	WD 2/25	110/4.3307	36/1.4330	66/2.5984	19/0.7480	33/1.2992	—	—	1,9/4.19
	WDL 2/25	130/5.1181	36/1.4173	66/2.5984	19/0.7480	33/1.2992	20/0.7874	—	2,1/4.63
	WDR 2/25	130/5.1181	36/1.4173	66/2.5984	19/0.7480	33/1.2992	20/0.7874	—	2,1/4.63
	WDPL 2/25	130/5.1181	50/1.9685	62/2.4409	31/1.2205	33/1.2992	20/0.7874	—	2,3/5.07
	WB 2/40	110/4.3307	51/2.0078	63/2.4802	Ø40/1.5748	—	—	—	1,8/3.97
3	WD 3/32	140/5.5118	44/1.7322	76/2.9921	25/0.9842	33/1.2992	—	—	3,0/6.61
	WDL 3/32	165/6.4961	44/1.7322	76/2.9921	25/0.9842	33/1.2992	25/0.9842	—	3,4/7.50
	WDR 3/32	165/6.4961	44/1.7322	76/2.9921	25/0.9842	33/1.2992	25/0.9842	—	3,4/7.50
	WDPL 3/32	165/6.4961	53/2.0866	66/2.5984	Ø31/1.2204	33/1.2992	25/0.9842	—	3,6/7.94

urret and Universal Quick Change System



Holder WDPL	Toolholder WB	Toolholder WBW	Boring Sleeve	Sleeve slottet (for dia. Ø)
1/12	WB 1/30	WBW 1/30	MK 1/30 MK 2/30	8, 10, 12, 15, 16, 20, 25
2/25	WB 2/40	WBW 2/40	MK 3/40 MK 4/40	10, 12, 15, 16, 20, 25, 32
3/32	WB 3/40 WB 3/50	WBW 3/40 WBW 3/50	MK 3/40 MK 4/40 MK 3/50 MK 4/50	20, 25, 32, 40
4/40	WB 4/60	WBW 4/60	MK 4/60 MK 5/60	25, 32, 40, 50
5/50	WB 5/80	WBW 5/80	MK 4/60 MK 5/60 + adapter for Ø 80	40, 50, 60 + adapter for Ø 80

Technical data

Size	Type	mm/inches N	mm/inches O	mm/inches P	mm/inches R	mm/inches S	mm/inches U	kg/lbs.
3	WDL 3/40	165/6.4961	44/1.7322	76/2.9921	25/0.9842	43/1.6929	25/0.9842	3,4/7.50
	WDR 3/40	165/6.4961	44/1.7322	76/2.9921	25/0.9842	43/1.6929	25/0.9842	3,4/7.50
	WB 3/40	140/5.5118	53/2.0866	66/2.5984	Ø40/1.5748	—	—	2,7/5.96
	WB 3/50	140/5.5118	63/2.4803	76/2.9921	Ø50/1.9685	—	—	3,5/7.72
4	WD 4/40	160/6.2992	53/2.0866	96/3.7795	30/1.1811	44/1.7322	—	5,0/11.03
	WDL 4/40	190/7.4803	53/2.0866	96/3.7795	30/1.1811	44/1.7322	30/1.1811	5,8/12.80
	WDR 4/40	190/7.4803	53/2.0866	96/3.7795	30/1.1811	44/1.7322	30/1.1811	5,8/12.80
	WDPL 4/40	190/7.4803	63/2.4803	96/3.7795	40/1.5748	52/2.0472	30/1.1811	6,5/14.34
	WD 4/50	160/6.2992	63/2.4803	96/3.7795	40/1.5748	54/2.1259	—	5,5/12.14
	WDL 4/50	190/7.4803	63/2.4803	96/3.7795	40/1.5748	54/2.1259	30/1.1811	6,0/13.24
	WDR 4/50	190/7.4803	63/2.4803	96/3.7795	40/1.5748	54/2.1259	30/1.1811	6,0/13.24
	WB 4/60	160/6.2992	77/3.0314	96/3.7795	Ø60/2.3621	—	—	6,0/13.24
5	WD 5/50	220/8.6614	67/2.6377	114/4.4881	40/1.5748	54/2.1259	—	9,6/21.18
	WDL 5/50	260/10.2359	67/2.6377	114/4.4881	40/1.5748	54/2.1259	40/1.5748	10,6/23.39
	WDR 5/50	260/10.2359	67/2.6377	114/4.4881	40/1.5748	54/2.1259	40/1.5748	10,6/23.39
	WDPL 5/50	260/10.2359	74/2.9133	114/4.4881	51/2.0078	54/2.1259	40/1.5748	10,5/23.17
	WB 5/80	220/8.6614	103/4.0550	115/4.5274	Ø80/3.1495	—	—	12,3/27.14

**Toolholders
for special applications**

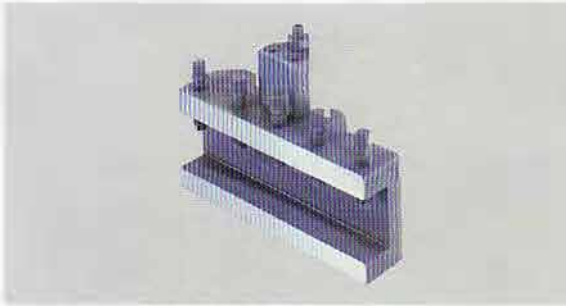

Size WDL with special length

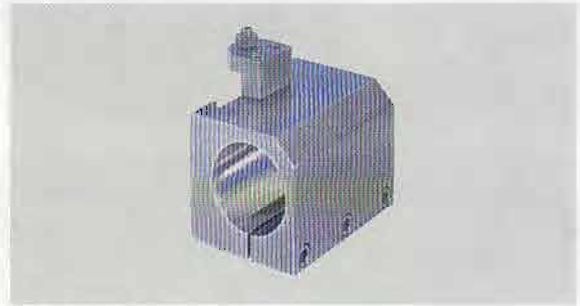

Size WB with special bore

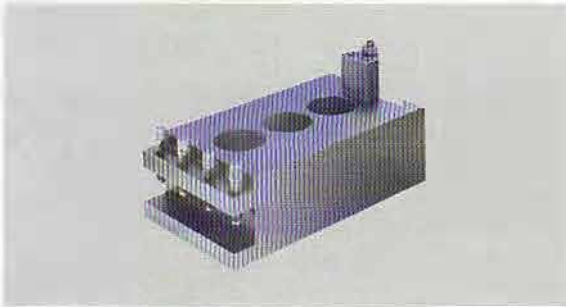

Size SP for large swing- dia. over bed of machine

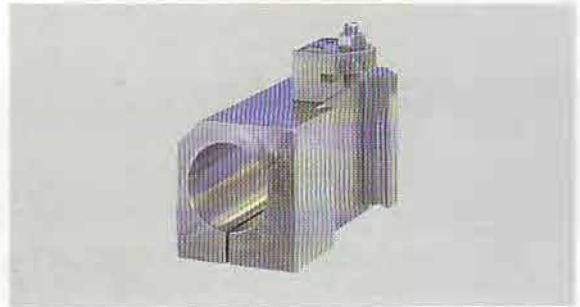

Size WB lengthened toward left

**PARAT
Werkzeugmaschinen GmbH**

Flurstraße 41
70372 Stuttgart, Germany
Phone: ++49 (0) 7 11/9 55 60-0
Fax: ++49 (0) 7 11/9 55 60-10
e-mail: info@parat-wzm.de



Your Partner of supply and technical
advice: